

Mixing Box Side View

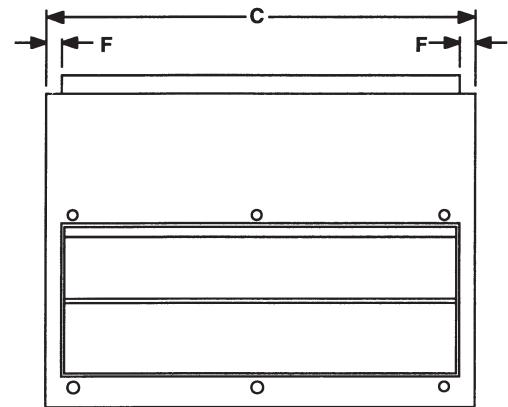

Mixing Box Rear View

Dimensions:

MODEL	A	B	C	D	E	F	DAMPER SIZE (NOM.)	SHIPPING WEIGHT
24AMB	16	16-3/8	18-1/8	8	6	1-1/16	2-16 X 8	40
36AMB	16	16-3/8	27-5/8	8	6	1-1/16	2-26 X 8	58
48AMB	18	20-3/8	29-1/8	10	8	1-1/16	2-27 X 10	65
60AMB	18	20-3/8	36-1/8	10	8	1-1/16	2-34 X 10	78
90AMB	18	25-3/8	45-1/8	10	8	1-1/16	2-42 X 10	110
120AMB	20	30-3/8	48-1/8	12	10	1-1/16	2-46 X 12	135
180AMB	22	37-7/8	57-1/8	14	12	1-9/16	2-54 X 14	190
240AMB	22	50-1/2	57-1/8	14	24	1-9/16	2-54 X 14	210

Features:

1. Cabinet fully insulated - 3/4 inch.
2. Attractive light gray epoxy finish on 24-60AMB. Embossed galvanized cabinet on 90-240AMB
3. Crank arms and linkage rod for damper connection are furnished. Connections can be made on either side of mixing boxes. The balance of necessary linkage hardware, damper motor, and controls to be field supplied.
4. Dampers can be positioned for either rear/top or rear/bottom locations.
5. 1" duct flanges provided on damper openings.
6. Dampers have air seals on the edges for positive closing. 24-90AMB have single horizontal damper blades. 120-240AMB have double horizontal damper blades.
7. When used with water coil units, a "freeze stat" must be installed to prevent coil damage caused by low ambient conditions.

Catalog No. ACMB107